

# INSTALLATION AND CARE GUIDE

---

## WOODBIDGE<sup>®</sup>

### Toilet + Bidet Seat



Compliance with the following Plumbing Codes & Standards:

- 2015 Uniform Plumbing Code<sup>®</sup> (UPC)
- 2018 International Plumbing Code<sup>®</sup> (IPC)
- WaterSense<sup>®</sup> Certified Toilet
- CSA B45.5 / IAPMO Z124-2017- Plastic Plumbing Fixtures

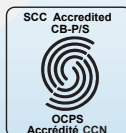

Customer Service Phone: 562-229-0088. (Monday - Friday 9 AM - 5 PM Pacific Time)

Or Email: [help@woodbridgebath.com](mailto:help@woodbridgebath.com)

[www.woodbridgebath.com](http://www.woodbridgebath.com)

20200818 REV. 1



## READ ALL INSTRUCTIONS BEFORE UNPACKING THE PRODUCT

INSTRUCTIONS THAT, IF IGNORED COULD RESULT IN DEATH OR SERIOUS INJURY CAUSED BY INCORRECT HANDLING OR INSTALLATION OF THE PRODUCT. THESE INSTRUCTIONS MUST BE OBSERVED FOR SAFE INSTALLATION.

**CAUTION!**



**TWO PERSON LIFT REQUIRED**

**2 PEOPLE ARE REQUIRED TO LIFT AND DURING ENTIRE INSTALLATION OF THIS PRODUCT**



**INSTALLATION OF THIS PRODUCTS BY AN INEXPERIENCED INSTALLER MAY RESULT PERSONAL INJURY OR DEATH!**



We reserves the right to change, update, modify, alter, redesign this manual/product or its policies without prior notice!

We shall not be liable for any injuries or property damages in connection with this product during installation or use of this product!

This products must be installed by a fully insured and licensed plumber only. Installation of any our product by anyone other than fully insured and licensed plumber shall void limited warranty. We recommends that such licensed plumber have experience in the installation of products.

Limited warranty is void on any commercial installation

We are not responsible for local code compliance for this product. Building and plumbing codes may vary from state-to-state in accordance to your location. We are not responsible for providing any compliance certifications.

Under no circumstances will we be liable for any and all incidental damages sustained in connection with this product

Neither manufacture, nor distributor, nor retailer is responsible for water damage or flood caused due to use of this product.

Under no circumstances will we be liable for any and all fees, cost of installation/reinstallation/removal, subsequent damage or transportation in case of the product defect

## TOILET COMPONENTS

**During unpacking the product and prior to installation inspect your new product for any damages or missing parts. Do not attempt to install or operate the product if the product is damaged.**



Bidet Seat X1



Nuts x2



Hand Wrench x1



One Pcs Toilet X1



Washers x2



Wax Ring x1



Closet Bolts x2



Toilet Template x1

## TOOLS REQUIRED FOR INSTALLATION



Soft Cloth or Blanket



Silicone

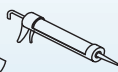

Silicone/ Caulk Gun

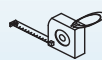

Tape Measure



Pencil/Marker



Safety Glass



Knife



Adjustable Wrench



Channel Lock Pliers

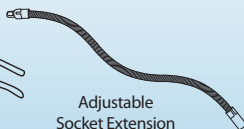

Adjustable Socket Extension



Phillips Screwdriver



Level



Putty Knife

OTHER TOOLS MAY BE REQUIRED

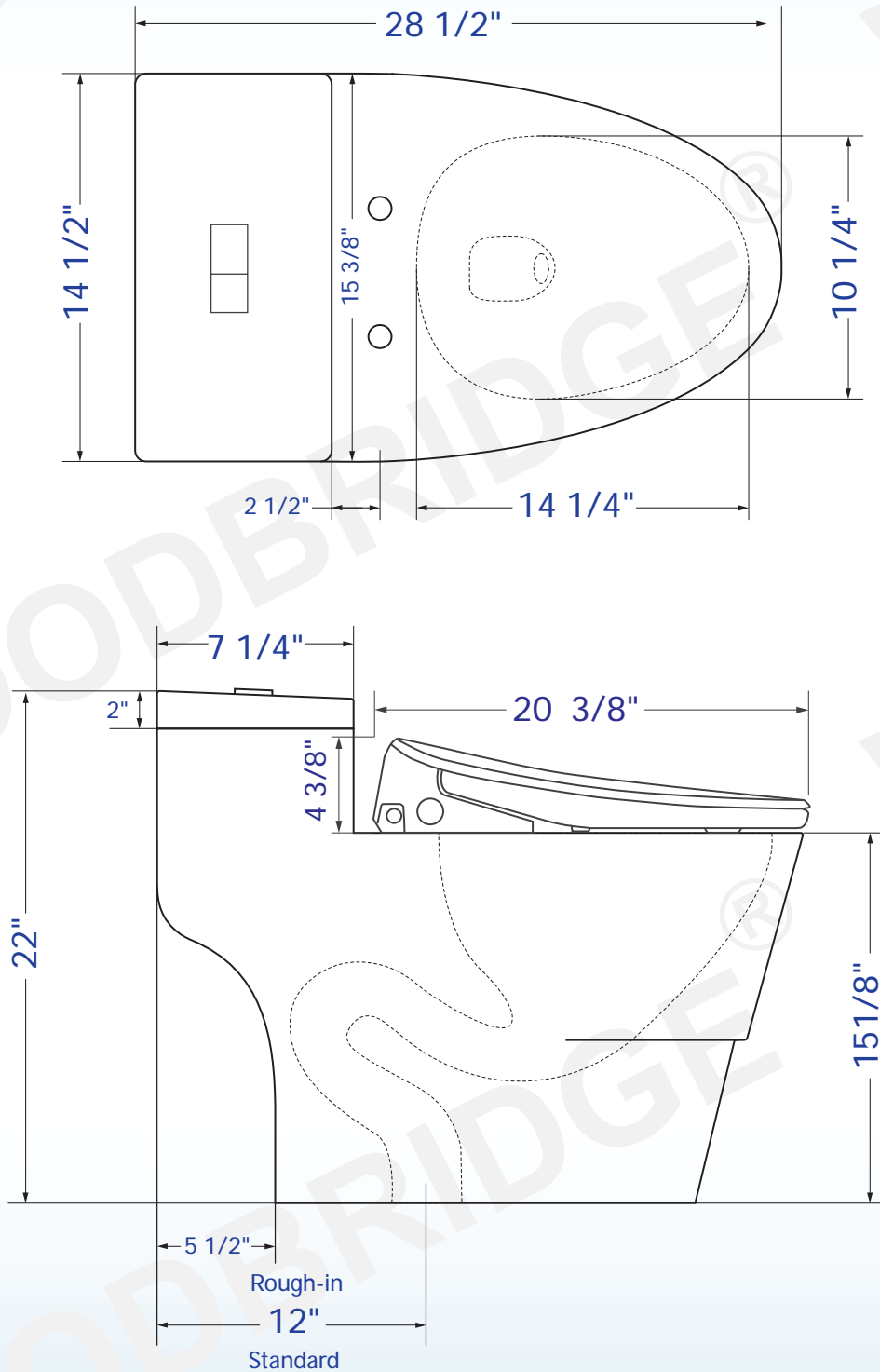

### IMPORTANT INFORMATION

- Measurements are  $\pm 3/8$ " and subject to change without notice
- Specifications & Configurations are subject to change without notice
- Please measure toilet on-site before installation
- Please note that installer(s) must be certified or warranty will be voided.
- Measurements herein supersede all others published prior to publication date shown below

## WATER SUPPLY LOCATION & TECHNICAL INFORMATION

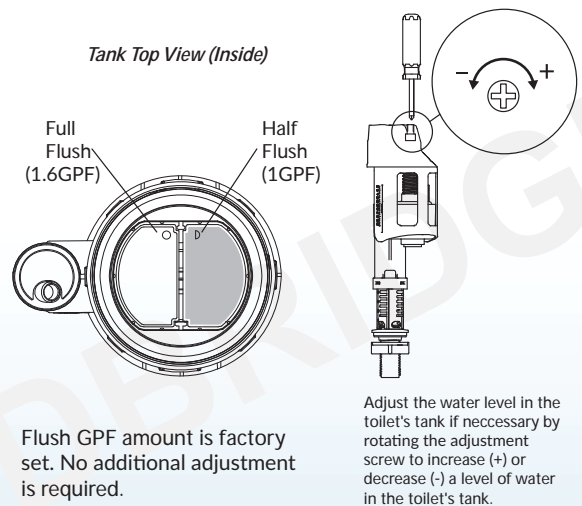
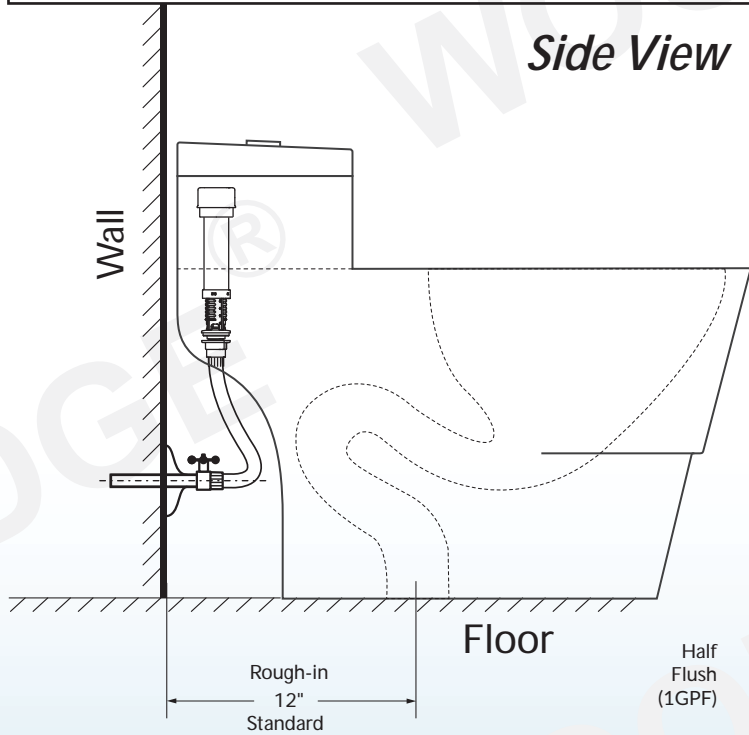
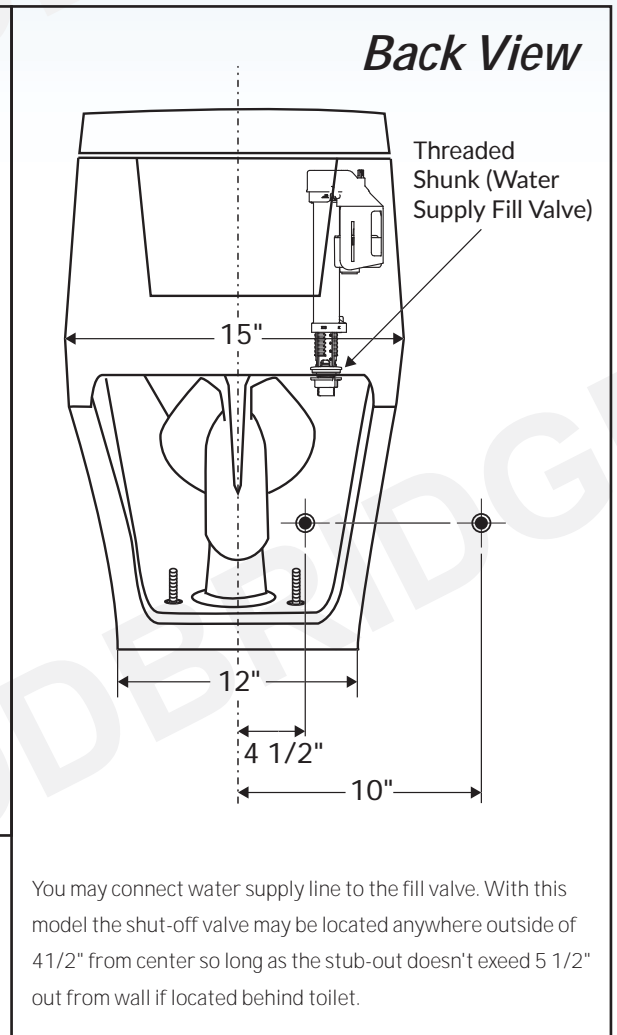
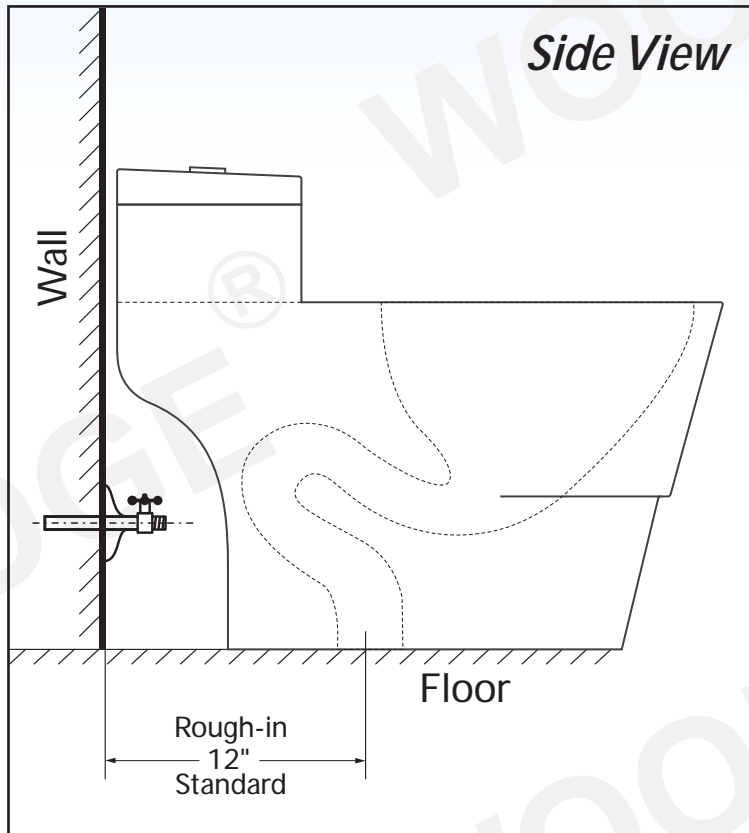

### IMPORTANT INFORMATION

- Measurements are  $\pm 3/8"$  and subject to change without notice
- Specifications & Configurations are subject to change without notice
- Please measure toilet on-site before installation
- Please note that installer(s) must be certified or warranty will be voided.
- Measurements herein supersede all others published prior to publication date shown below



**IMPORTANT! Shut off main water supply prior to installation!**

## REMOVE OLD TOILET

1. Shut off water supply line. If you do not have shut-off valve near the toilet shut off main water supply line.
2. Flush the old toilet and make sure that tank is empty.
3. Disconnect and remove water supply line connected to the toilet's tank.
4. Remove old toilet, bolts, nuts from the closet flange.
5. Clean closet flange area from old wax ring and putty sealant using putty knife from the base area.
6. Clean any remaining debris and wipe any water at the installation area
7. Temporarily plug flange on a floor with a flange plug or towel to prevent gasses from escaping

**IMPORTANT! The mounting surface area must be clean, dry, and leveled prior to installation of the new toilet!**

**NOTE! Inspect the existing closet flange for damages. If damaged, replace it to new flange before proceeding to the installation**

## PREPARE CLOSET FLANGE

Make sure that rough-in is 12" by measuring the distance from the wall to the center of the closet flange. See Figure 1

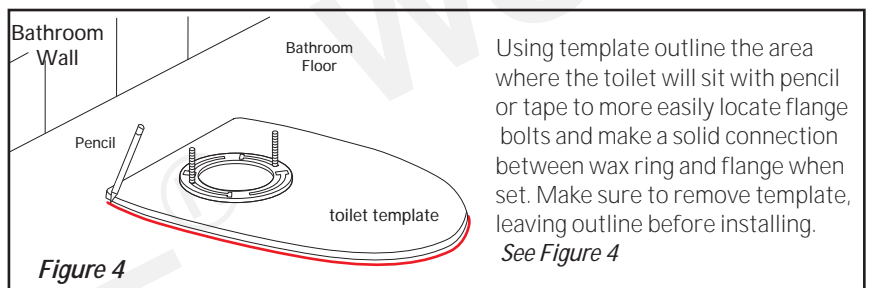
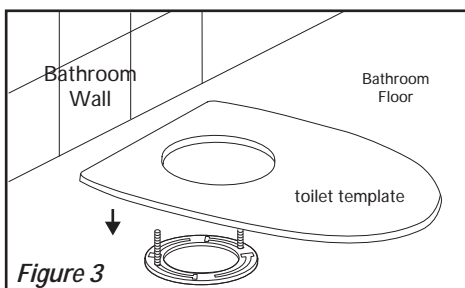
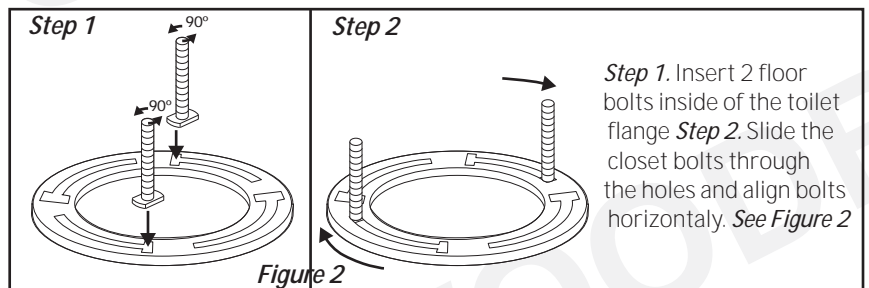
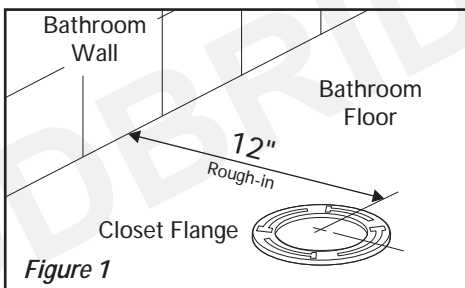

Using template outline the area where the toilet will sit with pencil or tape to more easily locate flange bolts and make a solid connection between wax ring and flange when set. Make sure to remove template, leaving outline before installing. See Figure 4

Locate and remove template from carton. Place over toilet flange. Measure from back wall to make sure it is square/even with wall. Check your shut-off valve to make sure it clears back of template. See Figure 3

## INSTALL WAX RING

**Important:** safety glasses must be worn by the installer and all bystanders.

Cover the floor with a soft-close blanket. Carefully turn the toilet on it's side or upside-down on the blanket with assistance of a second person. Install wax ring over the horn discharge located on the bottom of the toilet's bowl.

See Figure 5

**Note:** Ceramic is a fragile material. You must always cover the floor with a soft-cloth blanket if you want to put the toilet on the floor on any side other than the bottom of the toilet. If you do not cover the floor with a soft-close blanket contact of the toilet with the floor may and will cause minor or moderate scratches on the toilet's surface.

Prior to installation the wax ring must be kept in a room temperature between 70-75°F.

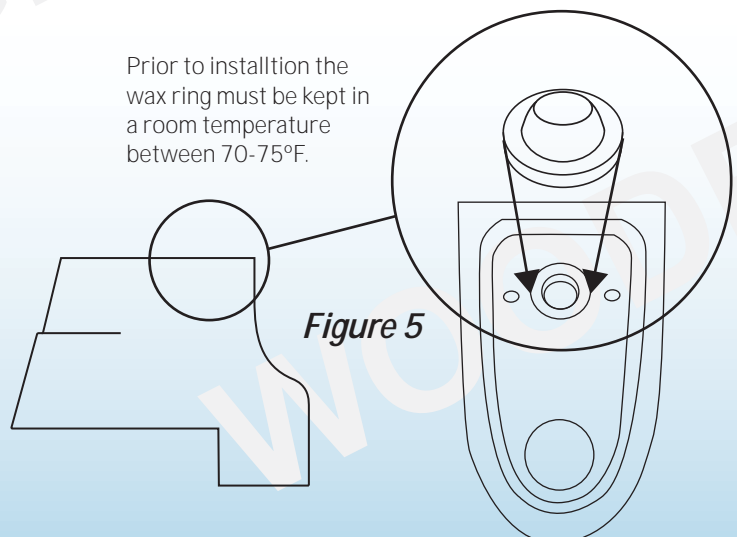

**Always Use Soft-Cloth Blanket**



### INSTALL NEW TOILET

**Step 1.** Lift and carefully put the toilet over the closet flange inside the outline made by template so the closet bolts can go through the mounting holes in the toilet's base. Once the bowl is in the position press the bowl down with slight twisting motion in level position towards the floor. Apply your body weight to evenly compress the wax ring to create watertight seal. Make sure that the bowl is as leveled as possible to have a nice seal tight.

Do not rock the toilet back and forth and side to side as it may and will break a seal and you will need to replace the wax ring again and start the installation process over.

See Figure 6

**Step 2.** Once the toilet is set and leveled install washers and nuts over the closet bolts. Tighten nuts. Do not overtighten the nuts. It may and will cause damage to the toilet's ceramic base. **Please keep in mind that because this is a skirted trap-way toilet, it may require a little more time, patience and accessibility to complete install.** See Figure 7

### CONNECT TOILET'S TANK TO WATER SUPPLY LINE

Connect the water supply line between the tank and water shut-off valve using a toilet hose (not supplied). When connecting toilet hose tighten coupling nut to the tank by 1/4 turn beyond the hand tight.



Do not overtighten nut on the tank connection. It may and will cause water leakage.

Turn on valve on water supply line and allow tank to fill. Check all connections for leakages and tighten as needed.

Once tank is filled with water flush it 4-5 times to perform a test of the flushing system. At the same time check the bottom of the toilet for leaks to make sure that the wax ring is properly installed and sealed.

If there are no leaks you are ready finalize the installation. If any shims are installed at the bottom of the toilet's bowl you may trim them. Apply silicone around base of the toilet's. Allow 24 hours for silicone to dry before start using the toilet. See Figure 8

**Important:** Leaks may not occur during or right after the installation. Make sure to check for leaks every couple hours first day installed and occasionally check it everyday for the next week to ensure that toilet is properly installed and no leaks occur. If any leaks occur immediately shut off the water supply line valve and contact your local plumber to fix all leaks.

**Important:**

Under no circumstances will we be liable for any and all incidental damages sustained in connection with this product

Neither manufacture, nor distributor, nor retailer is responsible for water damage or flood caused due to use of this product.

Under no circumstances will we be liable for any and all fees, cost of installation/reinstallation/removal, subsequent damage or transportation in case of the product defect

**CAUTION!**



**TWO PERSON LIFT REQUIRED**

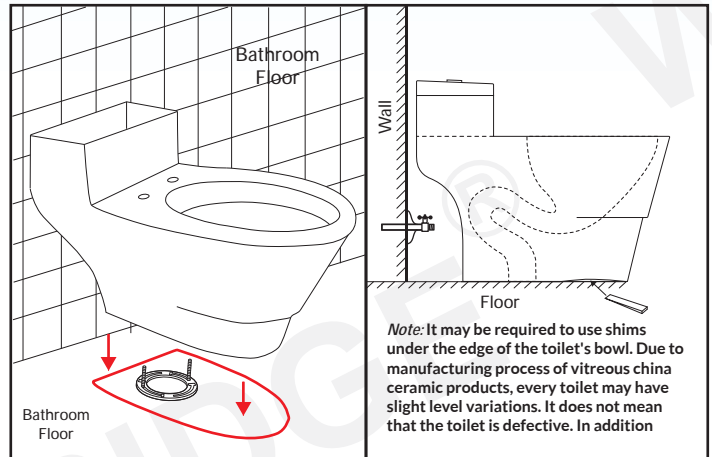

Figure 6

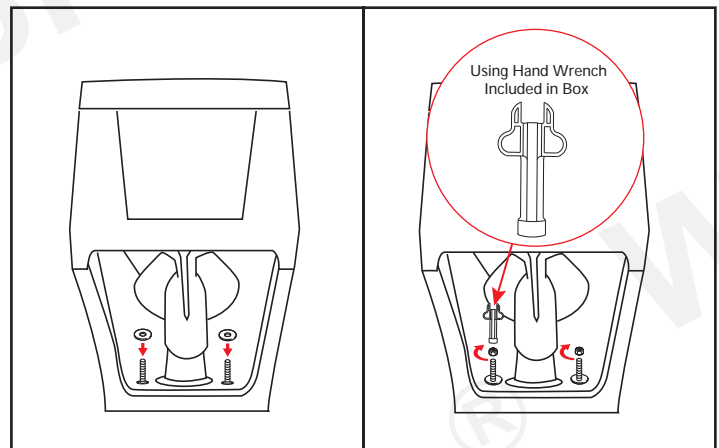

Figure 7

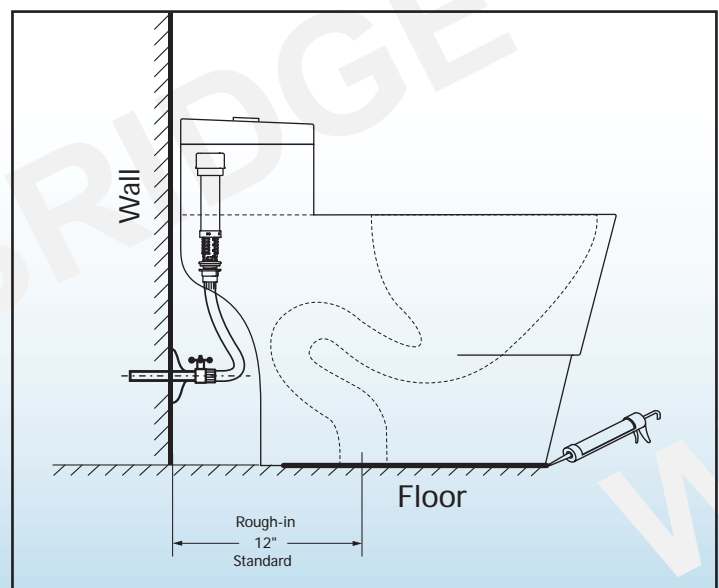
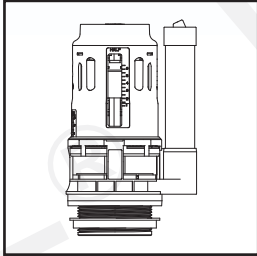

Figure 8



Important Note: Flush GPF amount is factory set. No additional adjustment is required. This page is for reference only. All adjustments are already made by manufacturer.

### 1. BASE INSTALLATION



Check the dual flush valve and make sure that it does not have any damaged or missing parts

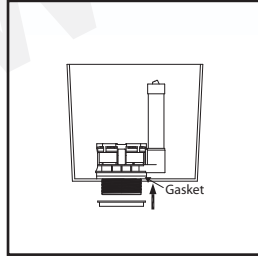

Install the base with the rubber gasket in the tank, turn the screw as illustrated to make sure there is no water leakage and no looseness

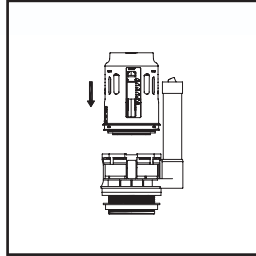

Install a body of the flush into the base and make sure they can be rotated clockwise arbitrarily.

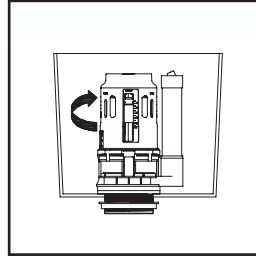

Rotate the valve clockwise to adjust its position inside of the toilet's tank

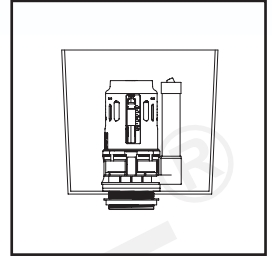

Install the sealing gasket

### 2. FLUSH VOLUME ADJUSTMENT

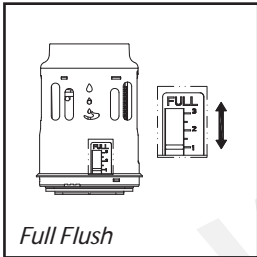

Full Flush

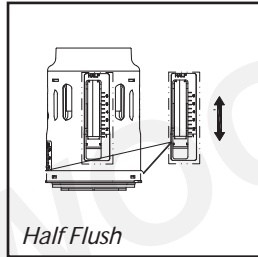

Half Flush

Full flush and half Flush range will decline when the button is moved upward from the bottom

### 3. PUSH BUTTON ADJUSTMENT

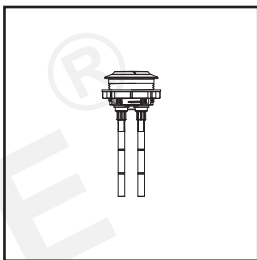

Check the completeness of the product before adjustment

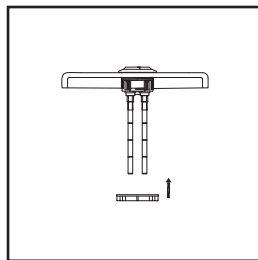

Take out the lock nut and insert the push button into the tank cover

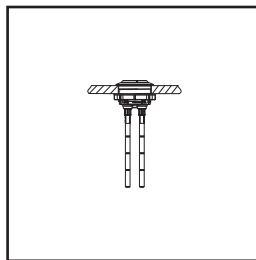

Adjust the push button and lock the nut to make it well-fixed in the tank

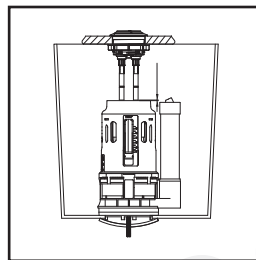

The distance between the rod tail and valve push button must be 1-2mm

### 4. REFILL TUBE ASSEMBLY

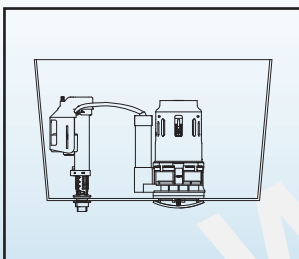

Put the refill tube into the white cap hole firmly

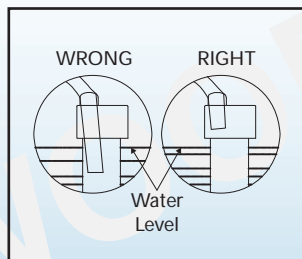

The refill tube can't be lower than the watersealing level

### TROUBLESHOOTING

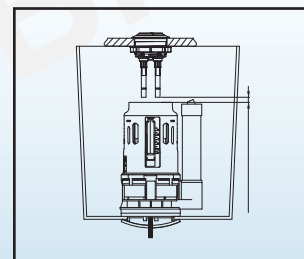

If the rod is too short, please re-adjust it (outward rotation).

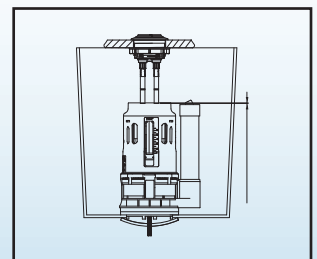

If the rod is too long please cut-off the extra length and re-adjust it.

**Important Note:** Flush GPF amount is factory set. No additional adjustment is required. This page is for reference only. All adjustments are already made by manufacturer.

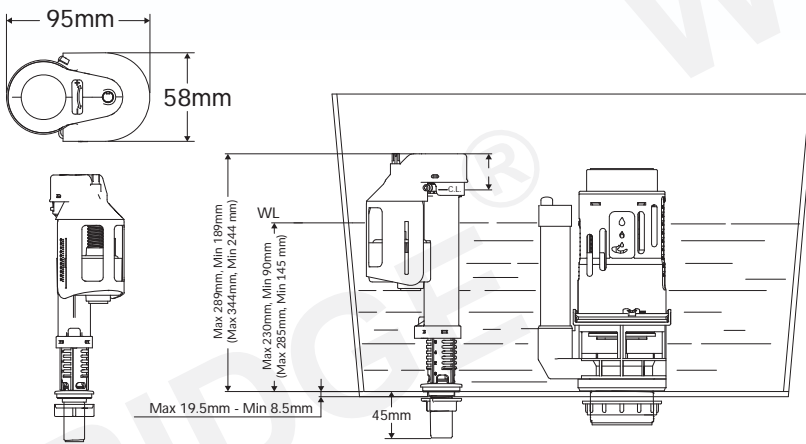

**Instructions:**

When valve installed, the critical level mark on fill valve (identified by C.L. mark on valve body) should be at least 1" above top of the over flow pipe.

**Required:**

- Water temperature: 36-112°F

**Important:**

Under no circumstances seller shall not be liable for any and all incidental damages sustained in connection with this product

Neither manufacture, nor distributor, nor retailer is responsible for water damage or flood caused due to use of this product.

Under no circumstances seller shall not be liable for any and all fees, cost of installation/reinstallation/removal, subsequent damage or transportation in case of the product defect

**IMPORTANT:** Do not use or drop any chlorine or any other chemicals. Use of chemical products will result in damage to the fill valve and flush valve components and may cause flood and property damage. Do not overtighten bolts/nuts as it may and will cause damage to the toilet parts and componets.

### 1. PREPARATION

Remove the worn-out fittings and clean your tank prior to the installation of the new ones. There might be a lot of impurities in your tank that may cause damage to the new parts if you do not clean them out. The tank must be absolutely clean prior to installation.

### 2. WATER LEVEL ADJUSTMENT

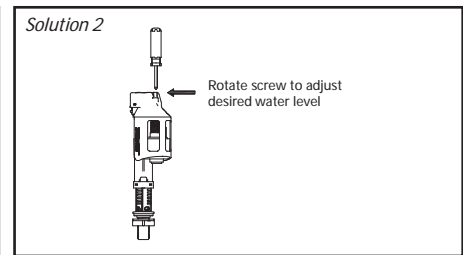
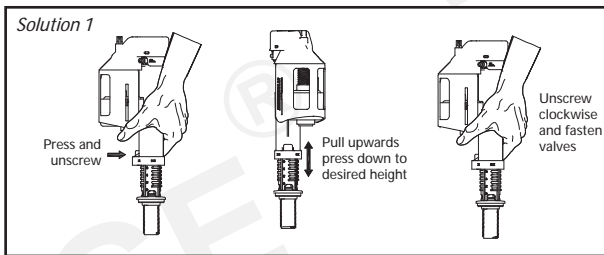
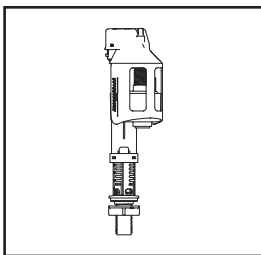

Check the fill valve and make sure that it does not have any damaged or missing parts

1. Press buckle and unscrew.
2. Pull the valve upwards or press down to desired height.
3. Unscrew the valve body and fasten the buckle

Rotating screw, rise or lower the water level to adjust water level to suitable position (water volume will gradually increase when the adjuster is moved upward from the bottom.)

### 3. FILL VALVE INSTALLATION

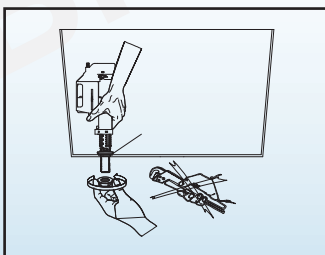

Install the valve into tank. Do not use any wrench tools. Fasten with hand only.

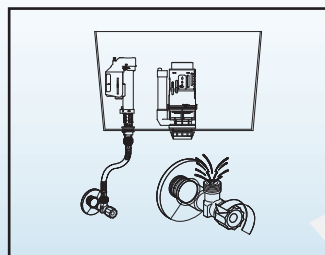

Connect water supply to the fill valve. Turn on water.

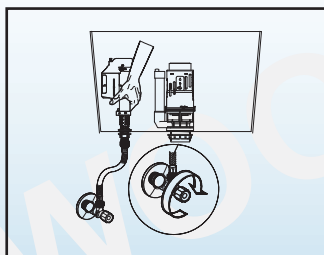

Turn off water supply valve before height adjustment of the toilet's fill valve.

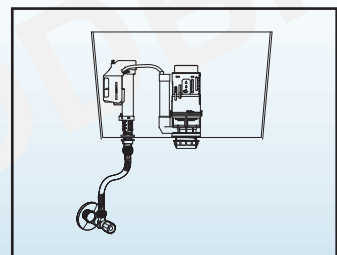

Put the refill tube into the white cap hole firmly.



### FILL VALVE CLEANING

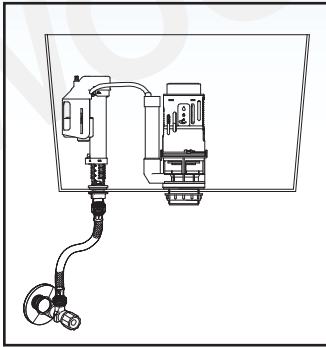

Shut off water supply line before filter cleaning.

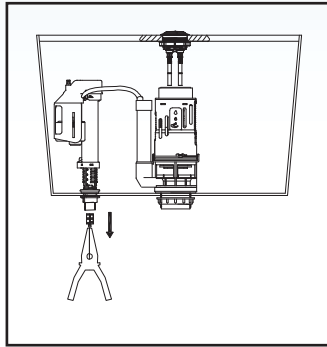

Carefully, take out the filter from inlet by using pliers.

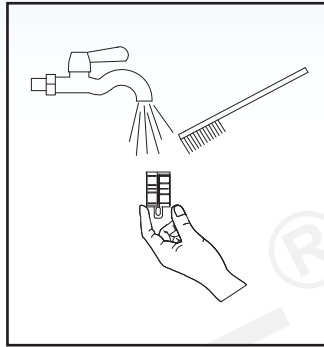

Use water to wash and clean the filter and adapter from any debris.

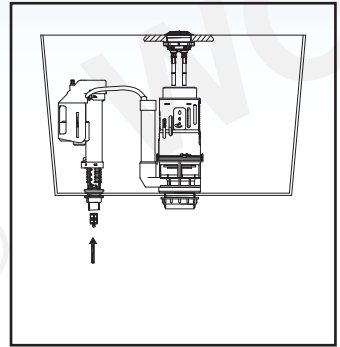

Re-install the filter and re-connect the water supply line.

### TROUBLESHOOTING

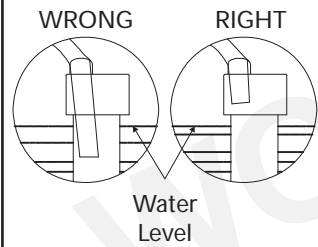
Issue	Cause	Solution	Solution #4  WRONG      RIGHT  
Water level is too high or too low	Improper water level adjustment	Adjust the water level	
Fill valve fails to shut off or fails to fill the water into the toilet's tank	<ol style="list-style-type: none"> <li>1. Inlet valve switch is turned on.</li> <li>2. Inlet valve float crashed against ceramic wall</li> <li>3. Filter screen is clogged due to dirty water</li> <li>4. Improper refill hose installation</li> </ol>	<ol style="list-style-type: none"> <li>1. Turn on inlet valve switch</li> <li>2. Adjust inlet valve position</li> <li>3. Clean the filter screen</li> <li>4. Install refill hose correctly (see diagram on the right)</li> </ol>	

### MAINTENANCE & CARE

Use soft sponges or soft-cloths to clean the surface. Always rinse thoroughly any cleaning solutions immediately after cleaning. Do not any chemical remain on the surface for extended periods of time.

#### IMPORTANT!

**DO NOT USE:** Abrasive cleaners such as: acid, ammonia, bleach, and similar solutions. Use of such solutions may cause corrosion, finish peeling, and/or dull the surface.

**DO NOT USE:** Abrasive sponges or cloth. Never use steel, wool, or wired brushes that will permanently scratch the surface.

### FILL/FLUSH VALVES MAINTENANCE & CARE

Do not pour any amounts of chlorine or any other chemicals into the tank. Use of chemical products will result in damage to the fill valve and flush valve components and may cause flood and property damage and will void warranty.

**Note:** fill and flush valves are maintenance free. No maintenance is required.

# Bidet Seat Installation Instructions

When using electrical products, especially when children are present, basic safety precautions should always be followed, including the following:

1. The appliance is not to be used by persons (including children) with reduced physical, sensory or mental capabilities, or lack of experience and knowledge, unless they have been given supervision or instruction.
2. Children being supervised not to play with the appliance.
3. This appliance can be used by children aged from 8 years and above and persons with reduced physical, sensory or mental capabilities or lack of experience and knowledge if they have been given supervision or instruction concerning use of the appliance in a safe way and understand the hazards involved.
4. Children shall not play with the appliance.
5. Cleaning and user maintenance shall not be made by children without supervision.

## READ ALL INSTRUCTIONS BEFORE USING



**DANGER**—To reduce the risk of electrocution:

1. Do not use while bathing.
2. Do not place or store product where it can fall or be pulled into a tub or sink.
3. Do not place in or drop into water or other liquid.
4. Do not reach for a product that has fallen into water. Unplug immediately.
5. Do not wash the main unit or electrical plug with water or detergent.
6. Do not handle the electrical plug with wet hands.
7. Do not put a hand or other staff over the outlet of air dryer or block the outlet of air dryer.
8. Never disassemble, repair or modify this product.
9. During installation, disassembly, repair and maintenance of the product, the power plug must be switched off and water supply be shut off.



**WARNING**—To reduce the risk of burns, electrocution, fire, or injury to persons.

1. Close supervision is necessary when this product is used by, on, or near children or invalids.
2. Use this product only for its intended use as described in this manual. Do not use attachments not recommended by the manufacturer.
3. Never operate this product if it has a damaged cord or plug, if it is not working properly, if it has been dropped or damaged, or dropped into water. Return the product to a service center for examination and repair.
4. Keep the cord away from heated surfaces.
5. Never use while sleeping or drowsy.
6. Never drop or insert any object into any opening or hose.
7. Do not use outdoors or operate where aerosol (spray) products are being used or where oxygen is being administered.
8. Connect this product to a properly grounded outlet only. See Grounding Instructions.
9. Do not throw cigarettes and other burning stuff into toilet, otherwise it might cause fire.
10. This product is electric appliance, so it must be placed far away from water. Please don't drench urine and other liquid to it.
11. Do not lay on side or upside the product during the electrical circuit.
12. It is prohibited to use other electric appliances in the same socket.
13. It is forbidden to use the power extension or unstable loose outlet.
14. The old aging water supply hose can not be used, otherwise it might cause leakage, fire or electrical shock. Installation of the bidet seat should include specified components and new water supply hose.



**CAUTION**—Indicates that failure to follow the instruction may cause body injury or property damage.

1. Do not install or use the product in wet places as steam room etc. This product must be connected to properly grounded power outlet socket.
2. It is recommended to use water-proof electrical outlet which should be installed in the place where is not easily got wet.
3. This product should be used with AC 110V-120V, 50/60Hz electrical current only, load current is at least 15A. Power plug must be equipped with ground fault circuit interrupter or ground fault electrical leakage protector or similar high sensitive, rapid type leakage switch (Rated sensitive current under 15mA).
4. When it thunders, it is strongly recommended to pull out the power plug.
5. Do not stand on ceramic toilet.
6. Ceramic toilet must install floor fixing bolt.
7. Do not stand on product unit, seat and cover.
8. Do not lean against the seat cover when using the product, to avoid damage.
9. This product is equipped with soft-closing seal cover. Heavy pressing or pushing may damage the soft-closing damper.
10. Do not use lacquer thinner, petrol, liquid medicine, detergent, insecticide, toilet cleanser and scrubbing brush to clean the product.
11. Exposure to direct sunlight is prohibited.
12. Only use tap water or potable water; otherwise it may cause chafing.
13. Do not connect water supply to heater outlet. Make sure inlet water temperature at 3~35°C
14. When the room temperature is under zero degree, please dry up the water tank, to avoid freezing.
15. Raise rest room temperature to prevent the toilet from damage due to freezing.
16. When move the product from cold or wet environment into normal room temperature, wait for 2 hours until the condensation water is fully volatilized. Doing so can prevent the product from electrical short-circuit.
17. When not using the product over three(3) days, drain the water out of the container and pull the electrical plug from the wall outlet.
18. Stop using the product and shut off the power when product malfunctions, please contact the service people for professional service.

## GROUNDING INSTRUCTIONS

This product should be grounded. In the event of an electrical short circuit, grounding reduces the risk of electric shock by providing an escape wire for the electric current. This product is equipped with a cord having a grounding wire with a grounding plug. The plug must be plugged into an outlet that is properly installed and grounded.



**DANGER** – Improper use of the grounding plug can result in a risk of electric shock.

If repair or replacement of the cord or plug is necessary, do not connect the grounding wire to either flat blade terminal. The wire with insulation having an outer surface that is green with or without yellow stripes is the grounding wire.

This product is factory equipped with a specific electric cord and plug to permit connection to a proper electric circuit. Make sure that the product is connected to an outlet having the same configuration as the plug. No adapter should be used with this product. Do not modify the plug provided — if it will not fit the outlet, have the proper outlet installed by a qualified electrician. If the product must be reconnected for use on a different type of electric circuit, the reconnection should be made by qualified service personnel.

**SAVE THESE INSTRUCTIONS**

<b>Main Unit</b>	Rating pressure	AC 110-120V,50/60Hz
	Rating power	1050-1250W
	Water pressure range	Minimum water pressure 0.07MPa (20L/min. flowing pressure). Maximum water pressure 0.8MPa (Hydrostatic pressure)
	Electrical wire	length is about 1.8m
<b>Cleaning device</b>	Container capacity	600ml
	Heating power	1000W
	Water temperature	6 different level adjustment
	Water volume	5 different level adjustment
	Cleansing mode	Rear cleaning/Rear massage,Front cleaning for ladies
	Spray cleansing location	5 different level adjustment
	Water pressure protector	Pressure stabilize,Automatic pressure discharging
	Anti-fouling device	Speedy water discharge device, Automatic nozzle cleaning, Anti-syphon device, Anti-backflow device, Filter device
	Safety device	Temperature controller, Thermal fuse, Ground protection, Leakage protection device, Air burning preventer
<b>Drying device</b>	Warm wind speed	Over 4 M/S
	Warm wind temperature	6 different level adjustment
	Heating power	250W
	Safety device	Temperature sensor, Temperature controller, Thermal fuse
<b>Heated seat</b>	Surface temperature	6 different level adjustment
	Heating power	50W
	Open and close device	Quiet soft-closing device
	Heated burning protection	The seat temperature will automatically lower to level 1 in 10 minutes after using
	Safety device	Seat sensor, Temperature sensor, Temperature controller, Thermal fuse
<b>Intelligent</b>	Night light assembly	Intelligent,often in the off state
	Mute setting	Buzzeroff during night
	User ID setting	To avoid disturbance from remote controls by multi-user

### Components Name

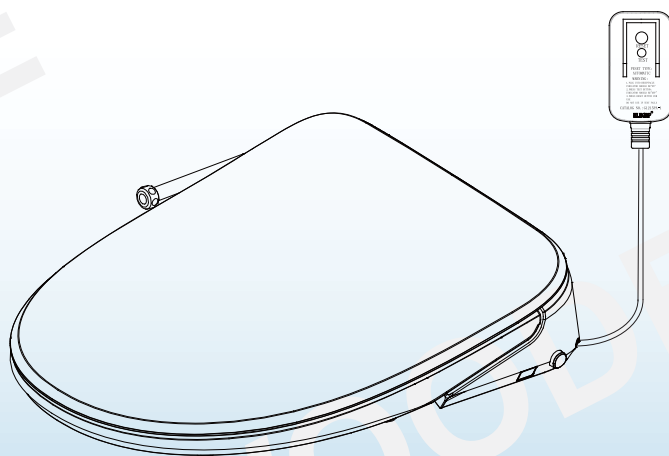
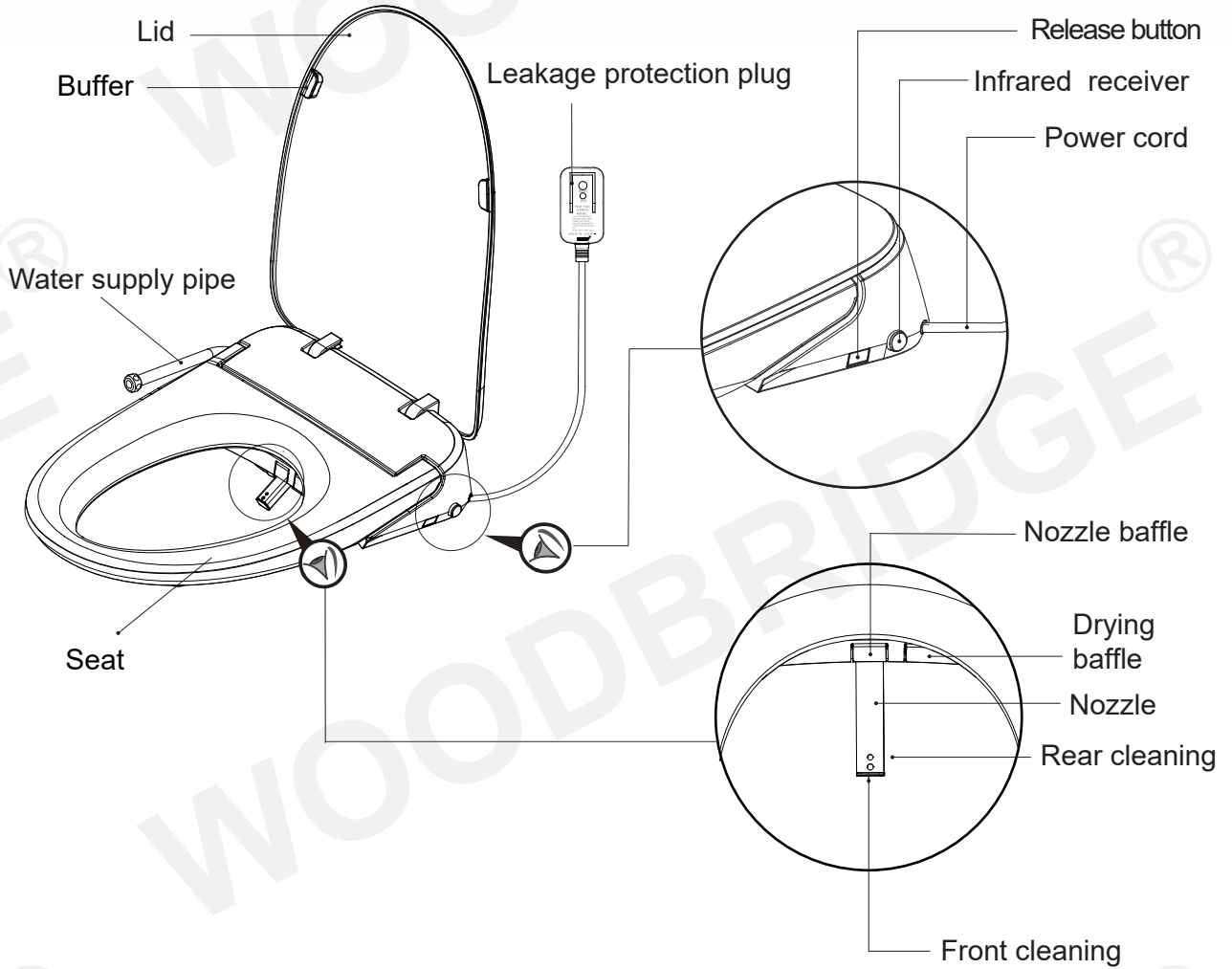

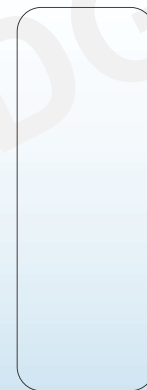

Whole set of product



The remote control

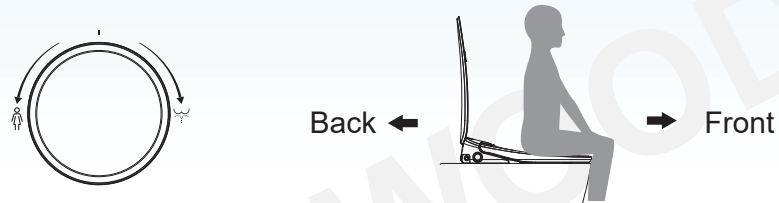

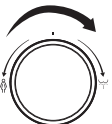
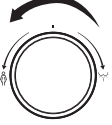
### Main Unit Knob Instructions (Knob Applies)



<b>Rear Cleaning Knob</b>	<ol style="list-style-type: none"> <li>1. When people is seated, turn Rear Cleaning Knob forward to start rear cleaning function; Rear cleaning (about 2.5mins) → Drying (about 5mins) → Stop drying automatically.</li> <li>2. During rear cleaning, turn the knob forward, the washing position moves forward, otherwise, the washing position moves backward.</li> </ol>	
<b>Front Cleaning Knob</b>	<ol style="list-style-type: none"> <li>1. When people is seated, turn Front Cleaning Knob backwards to start front cleaning function; Front cleaning (about 2.5mins) → Drying (about 5mins) → Stop drying automatically.</li> <li>2. During front cleaning, turn the knob backwards, the washing position moves backward, otherwise, the washing position moves forward.</li> </ol>	
<b>Stop Knob</b>	<p>Press the knob vertically to stop the function in progress: rear cleaning, front cleaning, drying or nozzle cleaning function.</p>	

### Main Unit Side Button Instructions (Button Applies)



 <b>Rear Cleaning Button</b>	<ol style="list-style-type: none"> <li>1. When people is seated, press Rear Cleaning Button shortly to start rear cleaning function; Rear cleaning (about 2.5mins) → Drying (about 5mins) → Stop drying automatically</li> <li>2. When rear cleaning function is on, long press Rear Cleaning Button to massage cleaning function; long press again to stop massage cleaning function.</li> <li>3. When the cleaning function is on, shortly press Rear Cleaning Button, the nozzle will move back by one step;</li> <li>4. When no one is seated, press Rear Cleaning Button, the nozzle will stretch out, people can wash the nozzle manually.</li> </ol>
 <b>Front Cleaning Button</b>	<ol style="list-style-type: none"> <li>1. When people is seated, shortly press Front Cleaning Button to start front cleaning function; Front cleaning (about 2.5mins) → Drying (about 5mins) → Stop drying automatically</li> <li>2. When front cleaning function is on, long press Front Cleaning Button to start massage cleaning function. Long press Front Cleaning Button again to turn off massage cleaning function.</li> <li>3. When cleaning function is on, shortly press Front Cleaning Button, the nozzle will move forward by one step.</li> </ol>
 <b>Stop Button</b>	<ol style="list-style-type: none"> <li>1. Long press Stop Button to make the main unit enter standby mode, press Stop Button again to make the main unit return to Operating mode. [In standby mode, all functions are invalid by pressing any button (on main unit or remote control) except Stop Button.</li> <li>2. When people is seated, shortly press Stop Button on main unit to stop front cleaning, rear cleaning or drying functions; When no one is seated, repeatedly press Stop Button on the main unit, the main unit will switch between operating mode and power saving mode.</li> </ol>



### Technical Specification

<b>Main Unit</b>	Rated voltage	110-120V , 50/60Hz
	Rated power	960W
	Water pressure range	The minimum necessary pressure 0.08MPa (hydrostatic pressure), the maximum water pressure 0.8MPa (hydrostatic pressure)
	Power Cord	length is about 1.6m
<b>Cleaning device</b>	Heating power	1400W(120V)
	Water temperature	6-level water temperature adjustment
	Water volume	5-level adjustment
	Cleaning mode	Rear cleaning / Massage cleaning, Front cleaning / Massage cleaning, Strong and weak washing (if applicable), Warm and cold cleaning (if applicable)
	Nozzle position	5-level adjustment
	Water pressure protector	Pressure stabilizer, Automatic pressure discharging device
	Anti-fouling device	Anti-syphon device, Anti-backflow device, Filter device
<b>Drying device (If Applicable)</b>	Safety device	The water temperature sensor, Anti-burning apparatus, Thermostat, Temperature fuse, Ground fault protection, Leakage protection , Anti-freeze cracking device
	Warm wind speed	Over 0.2m³/min
	Warm wind temperature	6-level adjustment
	Heating power	200W
<b>Deodorization</b>	Safety device	High temperature preventer, thermal fuse
	Deodorization Method	None Photocatalyst
<b>Heated seat</b>	Surface temperature	6- level adjustment
	Heating power	50W
	Open and close device	Soft close
	Prevent low temperature burn	After 10 minutes of use, the seat temperature will automatically drop slowly to a low level
	Safety device	Seat sensor, Temperature sensor, Bimetal thermostat, Thermal fuse
<b>Caring device</b>	Night light assembly	Smart, Always on, Always off
	Noise-free setting	The buzzer is off at night to avoid buzzer noise to guarantee a quiet environment at night
	User ID setting	To avoid disturbance from remote controls by multi-user
Sterilization device (If Applicable)		Plasma sterilization device
Antibacterial position		Seat, Nozzle

## Packing List

<b>The remote control assembly</b>	1.Remote control	<p>Remote control rack</p> <p>Remote control</p> <p>Batteries (3)</p> <p>Expansion screws (2)</p>
	2.Remote control rack	
	3.Expansion screws (2)	
	4.Batteries (3)	
<b>Base plate assembly</b>	1.Base plate	<p>Screws</p> <p>Fixed piece</p> <p>Floor</p> <p>Expansion nut</p>
	2.Screws (2)	
	3.Fixed piece (2)	
	4.Expansion nut (2)	
<b>The filter assembly</b>	Tee - joint (1)	<p>Tee - joint</p>
<b>Manual, Certificate of quality, Mounting Cardboard</b>	Manual(including warranty card)	<p>Manual (including warranty card)</p> <p>Certificate of quality</p> <p>Mounting Cardboard</p>
	Certificate of quality	
	Mounting Cardboard	
<b>Main unit</b>		

### Product Size and Installation Preparation Tool

<p>* Tips: Please confirm this seat fitting your current toilet.</p>	<p>Phillips screwdriver      Wrench</p> <p>Tape measure              Cup</p>
--	--

### Installation of Main Unit

- \* This product has been tested for water flow before leaving the factory. There may be a small amount of residual water dripping out when removing the product, which is not a malfunction.
- \* Do not install this product in a wet place such as a bathroom, and do not put it in a place prone to water.

<p><b>1 Installation of base</b></p> <p>Install Base plate      Screws</p> <p>Install Mounting Cardboard      Fixed piece</p> <p>Expansion nut</p> <p>Toilet mounting holes</p> <p>The black latch faces Forward, Groove up</p> <p>Install the expansion nuts into the toilet mounting holes first, and then install base plate, fixed piece and screws in sequence according to the above illustration, then tighten.</p>	<p><b>2 Installation and disassembly of Main Unit</b></p> <p>Installation of Main Unit: Align main unit to base plate and push it into the base plate, and a "click" sound means the main unit is installed in place. Disassembly of Main Unit: Press the "Disassemble button", and pull out the main unit when a "click" sound is heard.</p> <p>* Hand can leave "Disassemble button" after press it to pull out main unit.</p>
--	--

## 3 Installation of Water inlet pipe and Tee joint

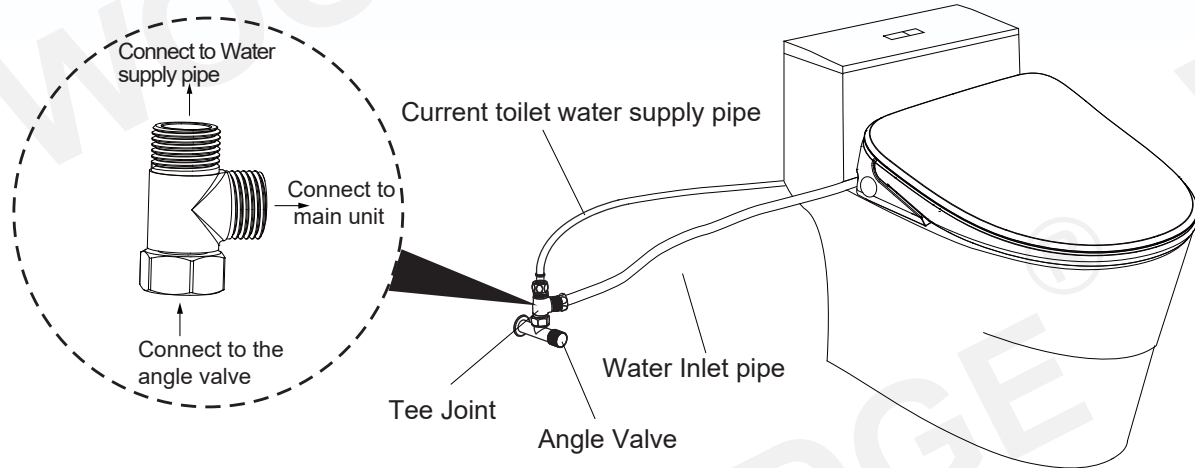

Connect Tee joint to angle valve; (The original Tee joint should be removed);  
Connect the inlet end of water supply pipe to Tee joint according to the above illustration;  
Connect main unit to Tee joint according to the above illustration.

### Preparation for Start-Up

#### 1. Turn on the angle valve

- Check the tightness of the threaded connection to ensure that there is no water leakage. Turn the angle valve counterclockwise to adjust the opening to the maximum.  
(Tips: when the valve is opened for the first time, the angle valve handle has a large torque)

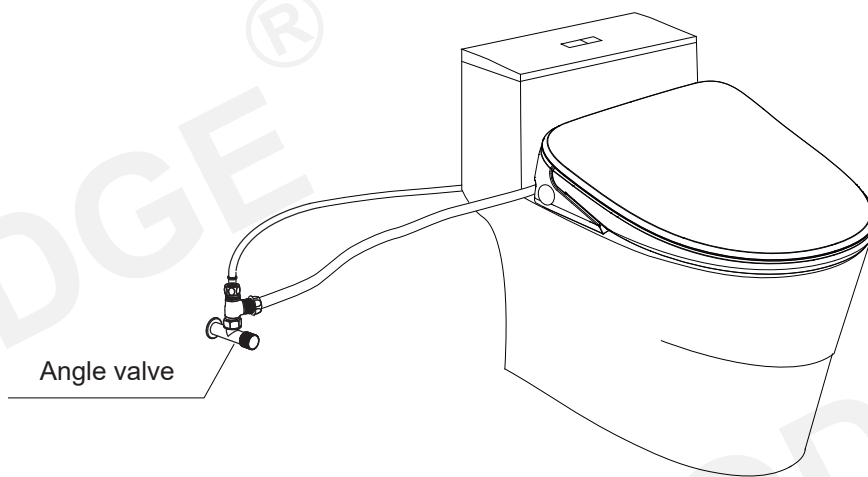

#### 2. Power Connection

- Insert power line leakage protection plug into the power socket, press the reset switch, plug indicator lights on indicating that the power is on.

#### Tips:

Press electric leakage test button prior to usage, the reset switch pops up indicating that the leakage protection function is normal.

Press the TEST button (then RESET button) every month to assure proper operation.

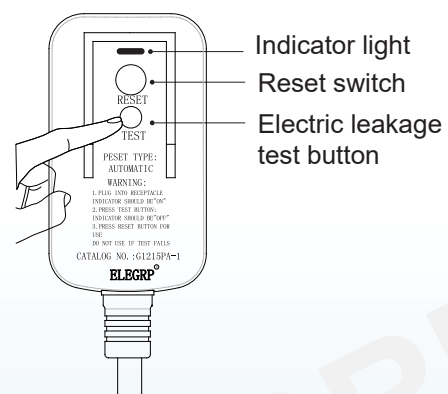

#### 3. Safety self-test

1. The main unit buzzer beeps once, and the knob (button) starts self-test after the white light flashes.
2. The main unit buzzer beeps again, and the self-test is completed, and the knob (button) lights up in white;
3. The function mode is turned on and in normal use.

# Daily Maintenance

## Maintenance of Main Unit

1. Turn off the power during maintenance of this machine.
2. Wipe the dirty area with a soft cloth that is wrung out of water.
3. After wiping, please turn on the power again.

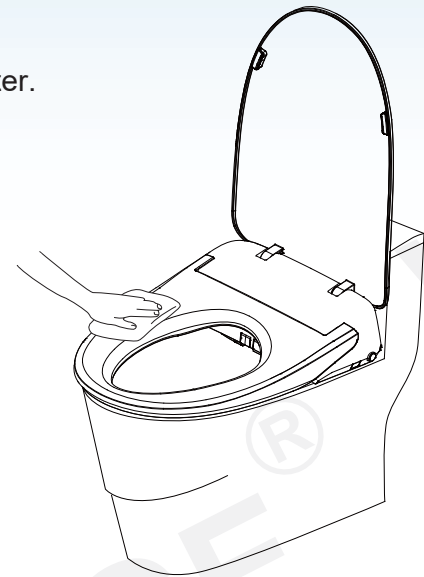
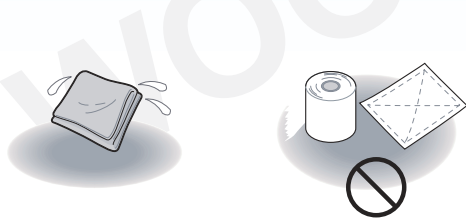

Tips: Do not rinse the surface of the product directly with water during maintenance.

## Maintenance of the Nozzle

When there is dirt on the nozzle, maintain it according to the following methods:

1. When no one is seated, turn the knob forward (press Rear Cleaning Button on the main unit), then nozzle rod is extended, and manually clean with a rag or soft brush.
2. Nozzle can be removed and cleaned separately. (Hold the nozzle rod in one hand and pull the nozzle out with the other hand)
3. Put back the nozzle, and then press the knob button (Stop button) on the main unit or the "Stop" button on the remote control, the guided rod retracts.

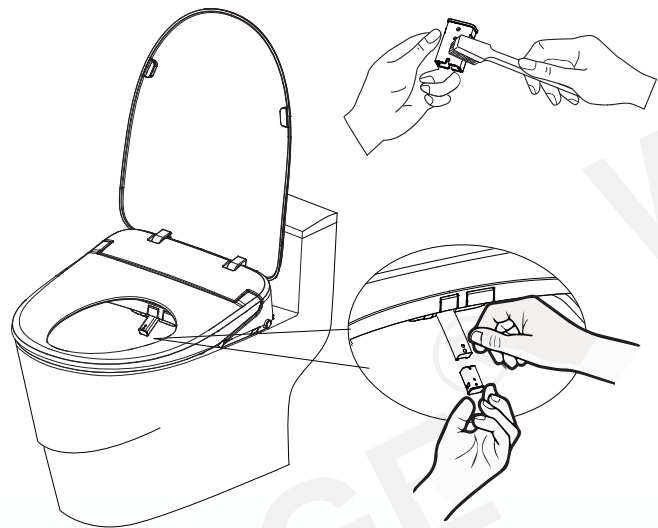
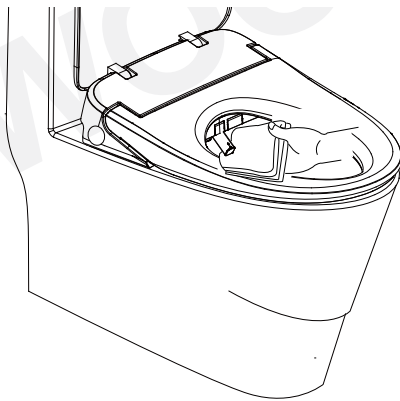

Tips: Do not pull the nozzle rod to prevent the damage of the nozzle rod and motor.

## Filter Maintenance

Time for maintenance: It is under normal water pressure but poor flush performance occurs.

1. Turn off the angle valve.
2. Unscrew toilet water inlet pipe and seat water inlet pipe.
3. Take out filter and filter washer
4. Brush filter with toothbrush and clean filter
5. Re-install filter and filter washer, then re-install water inlet pipe

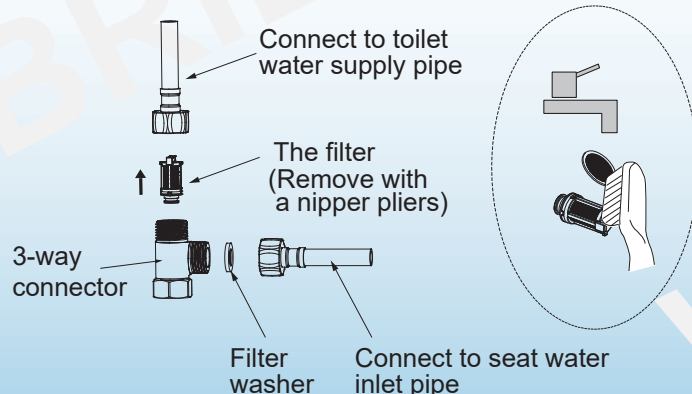



### Self-cleaning Waterway Maintenance

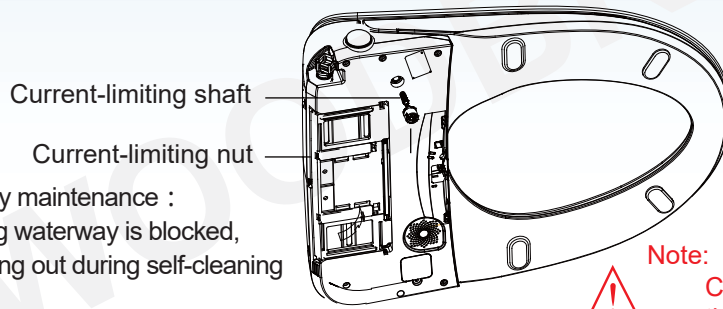

Self-cleaning waterway maintenance :  
When the self-cleaning waterway is blocked, there is no water coming out during self-cleaning process.

**Note:**  
 Cut off power prior to discharging the water.

1. Turn off the angle valve.
2. Unplug the power plug, cut off the power.
3. Remove the seat, press current-limiting shaft in the middle with a flat-blade screwdriver, then reinstall the seat, and open the inlet valve.
4. If there is still no water coming out after pressing current-limiting shaft, use a flat-blade screwdriver to unscrew current-limiting nut, remove current-limiting shaft, and clean it with a toothbrush or small brush. After cleaning, replace current-limiting nut and current-limiting shaft to the restrictor in the device, then reinstall the seat, and open the inlet valve.

### Deodorizing Device Maintenance

Unscrew the screws, take out the deodorant box, and replace the none-photocatalyst.

It is recommended to replace the none-photocatalyst after 3 years of use (the specific life span depends on the environment).

If you need to replace the none-photocatalyst, please purchase it in the official online store.

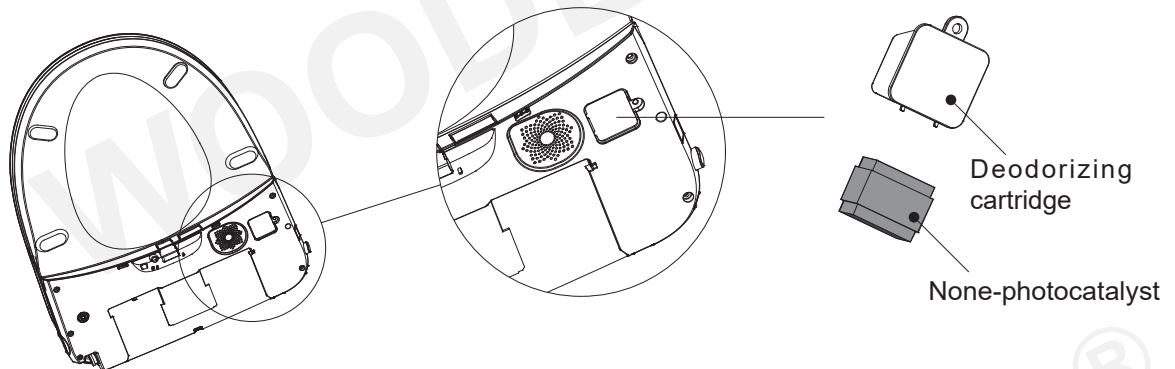

### Removal and Installation of Clamp

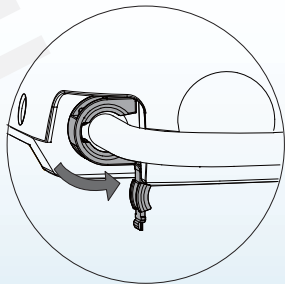

**Removal:** Open the clamp cover, rotate it counterclockwise, and use a flat-blade screwdriver to pry the clamp out of the slot.

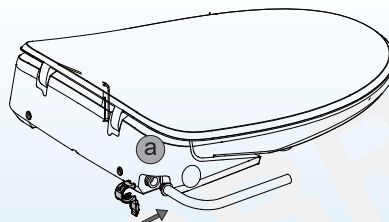

**Installation:** Install the quick-released connector of water inlet pipe into the main unit, and clip the clamp into the slot.

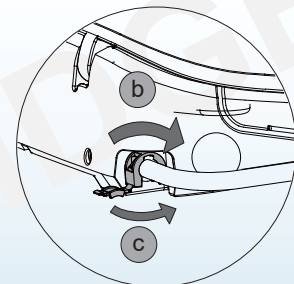

- b. The clamp is rotated until the opening faces down.
- c. Close the clamp cover

## Troubleshooting Guide

Problem	Cause	Solution
No Water from Nozzle	Water inlet hose bent to cause blocking	Solve the problem of bending of water inlet hose
	Inlet valve is off	Turn on the inlet valve
	Water supply is cut off	Connect water supply and wait for the water
Weak water cleaning	Water inlet hose bent to cause partial blocking	Solve the problem of bending of water inlet hose
	Water inlet valve is not fully open	Turn on the inlet valve fully
	Inlet filter blocked	Clean the filter
Low water temperature	The water temperature is set in normal temperature level	Reset the water temperature
low seat temperature	The seat temperature is set in normal temperature level	Reset the seat temperature
	In standby mode	Switch to operating mode and use it after 3 minutes
low wind temperature	The wind temperature is set in normal temperature level	Reset the wind temperature
No wind out	In standby mode or power saving mode	Shift to operating mode to use dry function
Nozzle rod cannot retract	Power off	Push back the nozzle rod lightly and put power on
	Get stuck by impurities	Clear away the impurities
Nozzle rod cannot stretch out	Power off	Put power on
	No sitting in sensing area	Sit right in the sensing area
Remote control cannot display	The battery of the remote control is installed in the opposite direction	Reload the battery
Malfunction of deodorization	User doesn't reach the sensing area in seat	Adjust to reach the sensing area
	Deodorization function keeps working after user leaves	It's a normal phenomenon if deodorization function keeps working after user leaves to ensure eliminating smell entirely
 <b>Caution</b>	If the problems cannot be solved as per above methods, please turn off the power , and contact service providers for maintenance.	
	If the power leakage protection switch always trips, it means that the product is leaking. Please turn off the power, contact the service provider, and ask for professional repairs.	

# Troubleshooting Guide

Problem	Cause	Solution
No Water from Nozzle	Water inlet hose bent to cause blocking	Solve the problem of bending of water inlet hose
	Inlet valve is off	Turn on the inlet valve
	Water supply is cut off	Connect water supply and wait for the water
Weak water cleaning	Water inlet hose bent to cause partial blocking	Solve the problem of bending of water inlet hose
	Water inlet valve is not fully open	Turn on the inlet valve fully
	Inlet filter blocked	Clean the filter
Low water temperature	The water temperature is set in normal temperature level	Reset the water temperature
low seat temperature	The seat temperature is set in normal temperature level	Reset the seat temperature
	In standby mode	Switch to operating mode and use it after 3 minutes
low wind temperature	The wind temperature is set in normal temperature level	Reset the wind temperature
No wind out	In standby mode or power saving mode	Shift to operating mode to use dry function
Nozzle rod cannot retract	Power off	Push back the nozzle rod lightly and put power on
	Get stuck by impurities	Clear away the impurities
Nozzle rod cannot stretch out	Power off	Put power on
	No sitting in sensing area	Sit right in the sensing area
Remote control cannot display	The battery of the remote control is installed in the opposite direction	Reload the battery
Malfunction of deodorization	User doesn't reach the sensing area in seat	Adjust to reach the sensing area
	Deodorization function keeps working after user leaves	It's a normal phenomenon if deodorization function keeps working after user leaves to ensure eliminating smell entirely
 <b>Caution</b>	If the problems cannot be solved as per above methods, please turn off the power , and contact service providers for maintenance.	
	If the power leakage protection switch always trips, it means that the product is leaking. Please turn off the power, contact the service provider, and ask for professional repairs.	

Thank you for using WoodBridge products!

Customer Service Phone: 562-229-0088. (Monday - Friday 9 AM - 5 PM Pacific Time)

Or Email: [help@woodbridgebath.com](mailto:help@woodbridgebath.com)



SCAN ME

# USER MANUAL BID 02

## WOODBIDGE®

### Remote Control Illustration

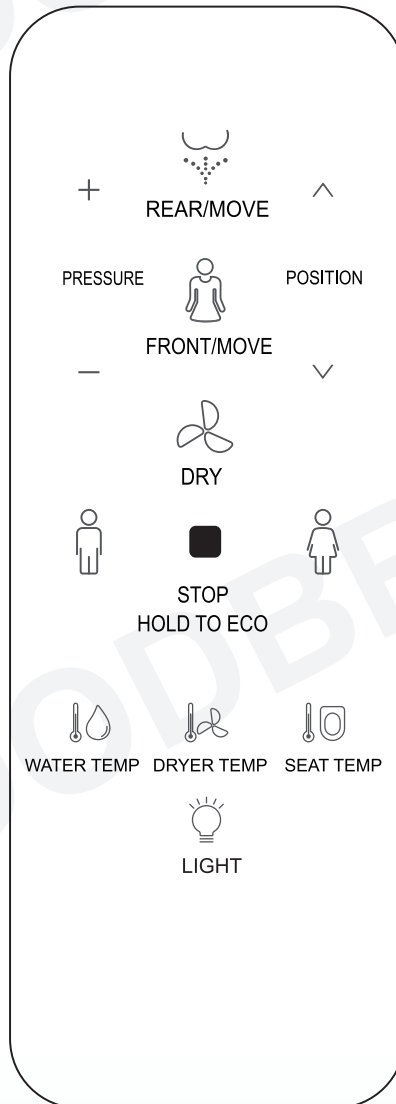

Thank you for choosing our product. Please read the instructions carefully before installation and keep it available for future maintenance or reference.

Customer Service Phone: 562-229-0088. (Monday - Friday 9 AM - 5 PM Pacific Time)

Or Email: [help@woodbridgebath.com](mailto:help@woodbridgebath.com)

2020413 REV. 2

## Installation Preparation

### Remote control installation

#### Remote control hanger installation

- (1) Place the remote control hanger upright on the pre-installed area of the wall and mark the location of the two mounting holes on the wall with a marker. Drill a hole in the marked position on the wall with a drill bit of 6 mm in diameter, with a depth of 35 mm. (When determining the installation location, note that when the person sits on the seat to ensure that the user can catch the remote control.)

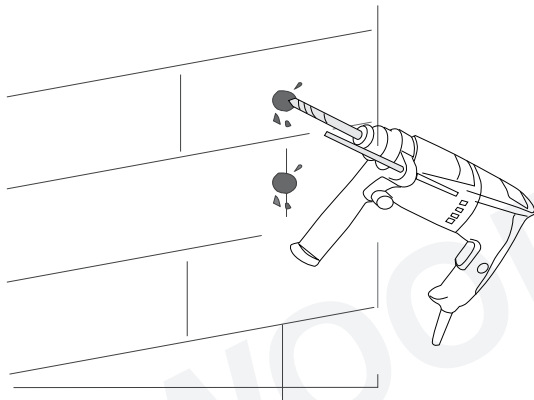

- (2) Put the expansion tube into the wall hole and the hanger is tight against the wall. Align the hole in the hanger with the expansion tube and tighten the screw, and then cover the silicone gasket.

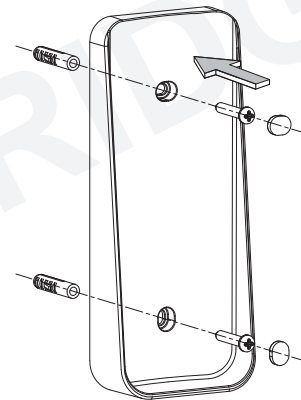

- (3) Put batteries into remote control and cover remote control.

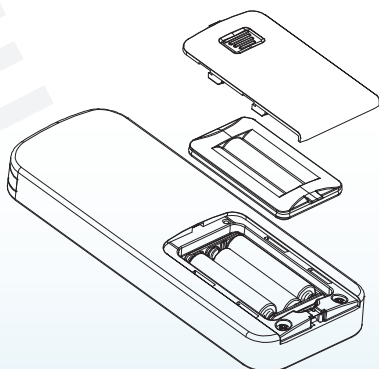

- (4) Put remote control to the hanger.

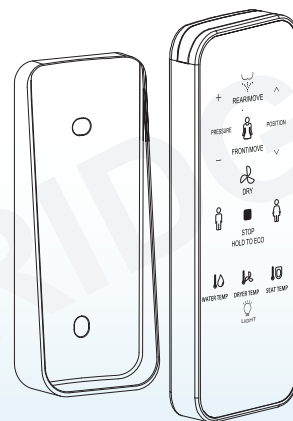

Notice : Don't install and use the product in damp places such as shower room.  
Don't place the product in a place where it is easily exposed to water.

## Installation Preparation

### Remote control installation

Remote control hanger installation (Only for the hanger matching with fixing board and foam gasket.)

- (1) Clean and dry the pre-installed area of the remote control rack on the wall. (When determining the installation location, make sure that the user can reach remote control when he sits on the seat.)

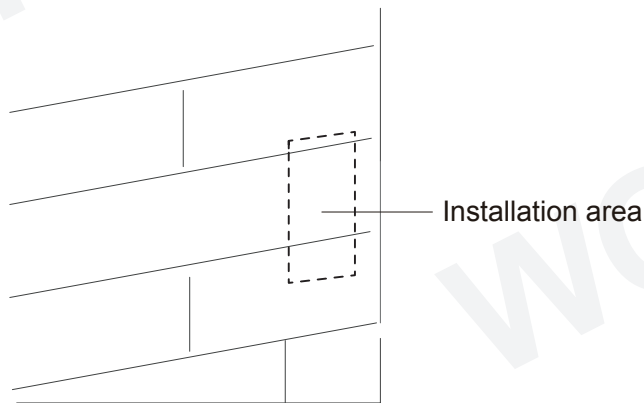

- (2) Remove the adhesive tape on the back of the hanger and place it tightly against the wall, then cover the silicon gasket.

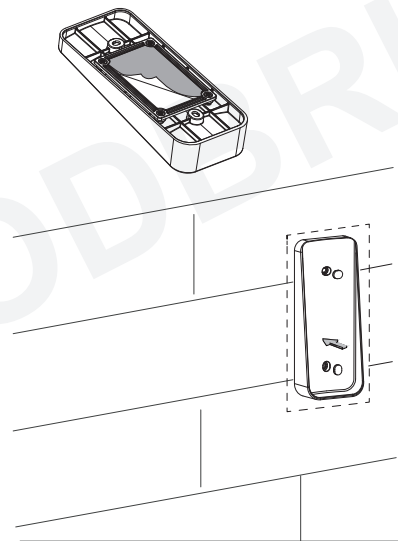

- (3) Put batteries into remote control and cover remote control.

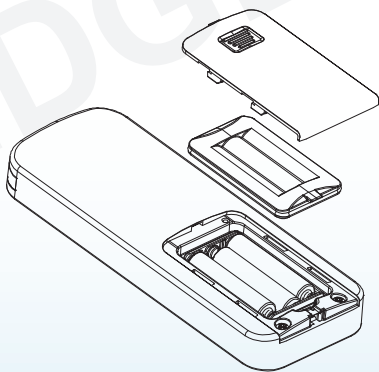

- (4) Put remote control to the hanger.

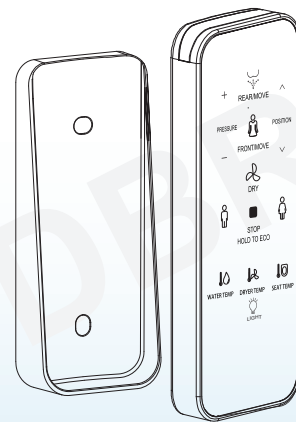

Notice : Don't install and use the product in damp places such as shower room.  
Don't place the product in a place where it is easily exposed to water.



**Usage Instruction**

**Remote control illustration**

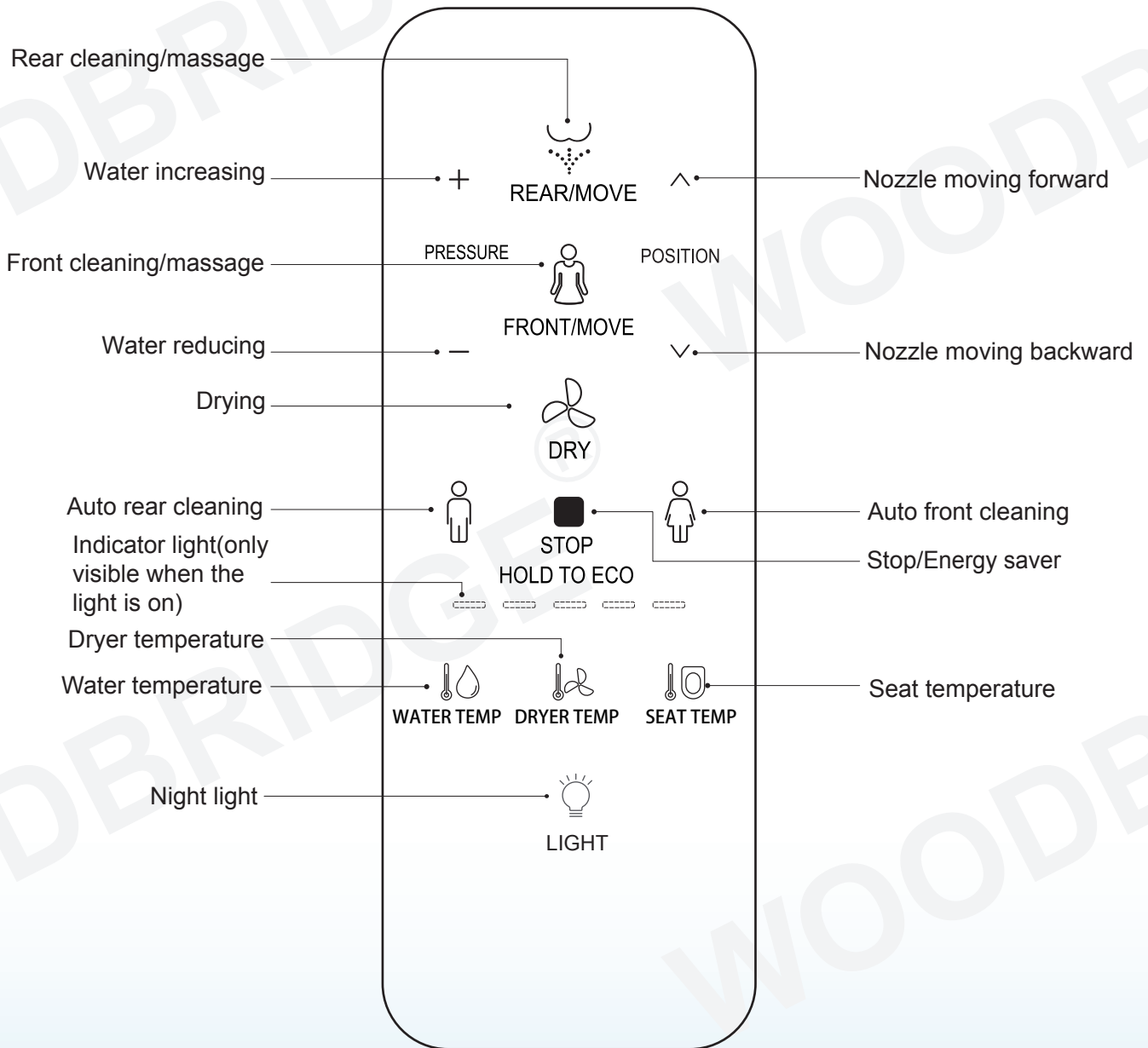

## Usage Instruction

### Rear/Front cleaning

- Press “Rear cleaning/massage” button, the indicator light is on showing current water temperature level, it starts rear cleaning; Press again “Rear cleaning/massage” button to shift to massage cleaning (nozzle moves forward and backward to expand cleaning area). The cleaning will last for a circle and stop automatically, while it will stop immediately if the user presses “STOP” button.
- Press “Front cleaning/massage” button, the indicator light is on showing current water temperature level, it starts front cleaning; Press again “Front cleaning/massage” button to shift to massage cleaning (nozzle moves forward and backward to expand cleaning area). The cleaning will last for a circle and stop automatically, while it will stop immediately if the user presses “STOP” button.

### Drying Operation

- Press “Dry” button, the indicator light is on showing current wind temperature level, it starts drying; it will stop drying automatically after a circle or the user leaves the seat.

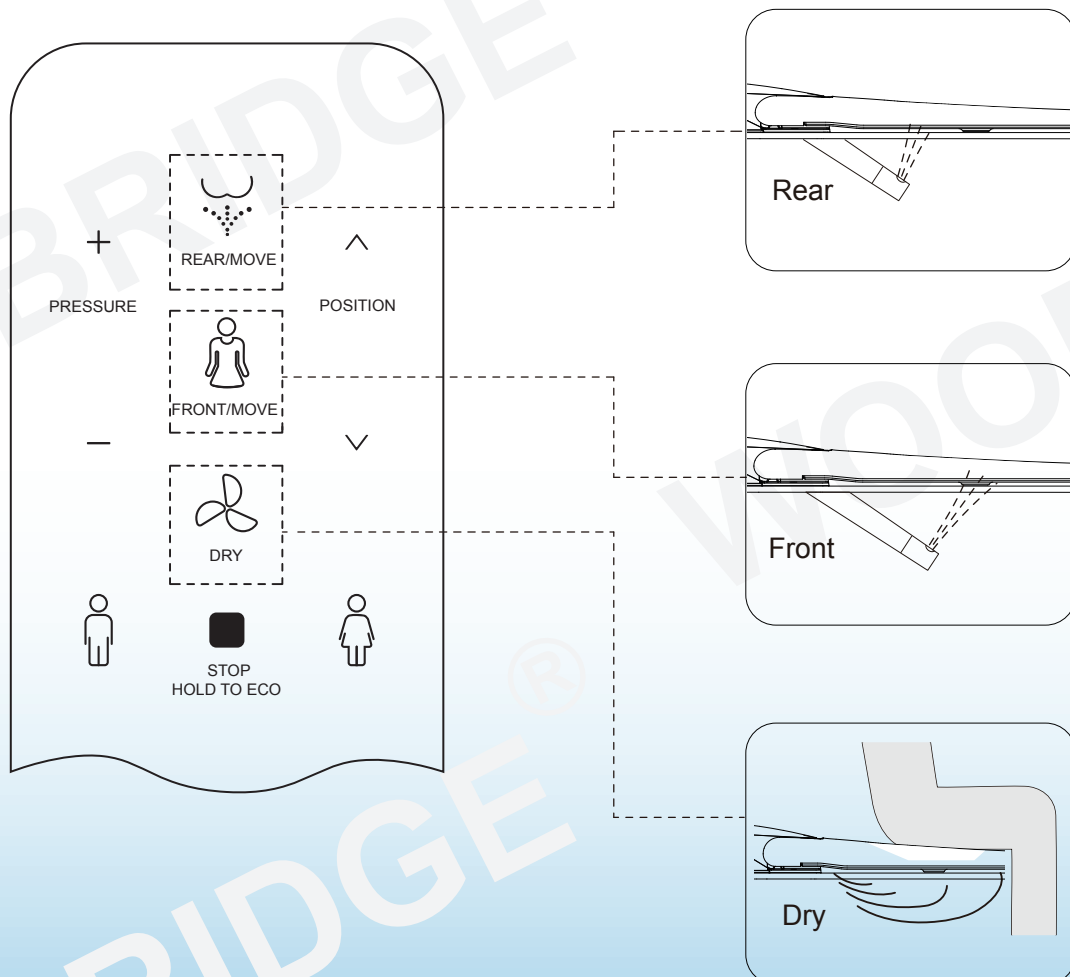

## Usage Instruction

### Water volume adjustment

- Press “+” or “-” button when it is under function of rear cleaing or front cleaning, the indicator light will be on showing current water volume level, adjust water volume by levels.

### Spray nozzle position adjustment

- Press “^” or “v” button when it is under function of rear cleaing or front cleaning, the indicator light will be on showing current nozzle position, adjust nozzle position by 5 levels.

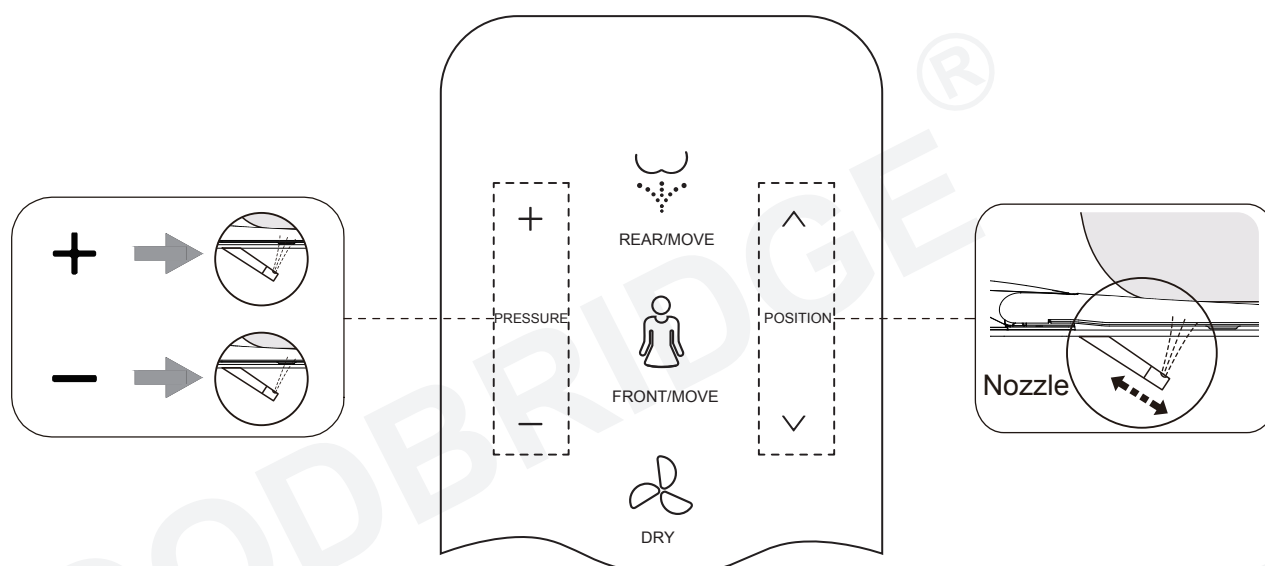

## Usage Instruction

### Energy saver

Keep pressing "STOP" button for more than 3S to enter energy saving mode, the indicator light will be off and energy saving light will be on. Keep pressing "STOP" button again for more than 3S to exit energy saving mode, the indicator light will be on and energy saving light will be off.

### Energy saving

Under energy saving mode, seat temperature is low(level 1) to achieve energy saving. (Note: If the seat temperature before energy saving is neutral, keep the neutral after energy saving)

### Remark

Energy saving mode will be suspended and goes to function mode if someone uses the seat in the middle of energy saving. The seat starts to heat immediately (without closing the seat temperature), and the energy saving mode is restored after the human body leaves the seat.

### Auto function

- The automatic function of factory default setting is middle level for water volume, nozzle position, water temperature, air temperature, seat temperature.
- Short press on the remote control button "♂", "♀" can achieve male hip wash and female bidet wash, fully automatic and convenient use. The user can firstly set the water volume, nozzle position, water temperature gear position and air temperature gear position. After the setting is completed, press the corresponding automatic key 3s to save the setting. The next time you use it, you can call the saved key by pressing the corresponding automatic key. Set the automatic function to enable automatic cleaning and drying in the whole process.
- The Auto function mode will be off if the user presses other buttons during operation of auto functions and shift to operate the functions of the buttons.

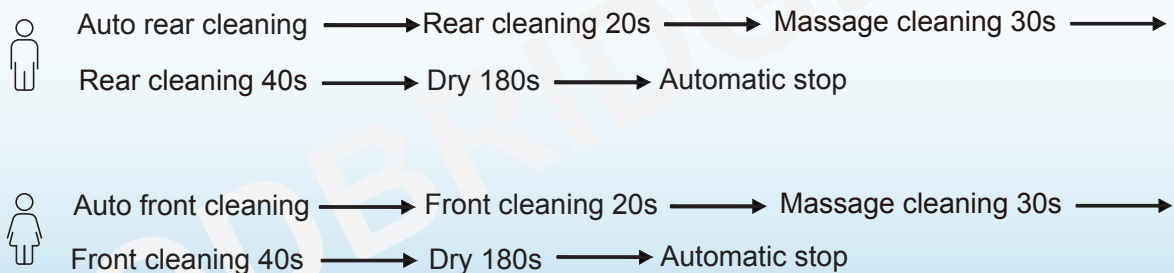

Tips: Certain models don't have drying function.

**Usage Instruction**

**Temperature adjustment**

· **Water temperature adjustment**

Short press the “WATER TEMP” button to adjust the water temperature. The indicator will show the water temperature level if it’s on. When the indicator is off, the water level is 0. Short press this button to adjust water temperature level from 0 to 5 in cycle. (Note: the water temperature is set at 10±2.5°C in level 0, that is, when the inlet water temperature is higher than 10°C, the water won’t be heated, while when the inlet water temperature is lower than 10°C, the water will be heated to about 10°C.)

· **Dryer temperature adjustment**

Short press the “DRYER TEMP” button to adjust the dryer temperature. The indicator will show the dryer temperature level if it’s on. When the indicator is off, the wind level is 0. Short press this button to adjust dryer temperature level from 0 to 5 in cycle.

· **Seat temperature adjustment**

Short press the “SEAT TEMP” button to adjust the seat temperature. The indicator will show the seat temperature level if it’s on. When the indicator is off, the seat level is 0. Short press this button to adjust seat temperature level from 0 to 5 in cycle.

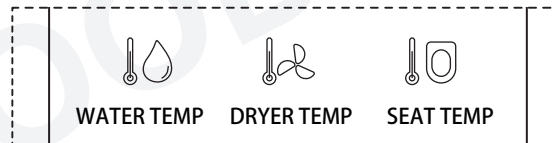

**Night light** (Only for toilets with night light function)

· Short press “Night light” button to turn on/turn off night light, long press “Night light” button to enter into intelligent mode ( Night light will be on or off by detecting the lightness of surroundings). If the product is on intelligent mode, short press “Night light” button to exit intelligent mode.



## Usage Instruction

### Other Operations

#### User Code

- The user code needs to be set to avoid disturbance from remote controls when more than one smart toilets are used in the house. Turn on the toilet for setting while turning off others. Press user code combination buttons (Press “STOP” button first and then press “REAR” button) to enter user code setting mode, the indicator lights will be on and keep flashing.
- (RF remote control) The Remote control will generate matching user code automatically, press user code combination buttons again to exit setting mode and setting is completed. When the main unit is powered off to restart or change remote control batteries, user code won't be cleared and no need to reset.
- (IR remote control) Press water volume “+”“-” buttons to select user code. The indicator shows the corresponding user code. Press the user code combination buttons again to save settings and exit. The buzzer beeps and it's set successfully. When the main unit is powered off to restart or batteries are removed from remote control, the user code will be cleared and need to be reset. After entering setting mode, if there's no operation for 10s, the remote control will exit setting mode automatically and return to previous states.

#### Quit mode

Long press “SEAT TEMP” button to turn on/off quit mode.

#### Auto deodorization

Press “Stop” button first and meanwhile press “FRONT” button to start or close auto deodorizing function; While the auto deodorization function is on, when it's detected that the user is seated, it'll start deodorizing and stops when user leaves above 3s. The auto deodorization function will turn off automatically during drying. (This function only applies to product with auto deodorization function. This function is set to on by default.)

#### Remark:

- The buzzer will sound “BEEP” when the user presses one button which means the main unit receives the signal and conduct the operation accordingly. If the buzzer doesn't sound, it means the main unit doesn't receive the signal, please adjust the remote control direction and repress the button.
- In case of power cut during wand's spray operation, the wand cannot go back to place, please wait until the power is reset. In case of a power cut for a long period, please push the wand softly back by hand. Do not push hard, to avoid damage to wand and electrical machine.
- The body should touch the seat and the buzzer rings “CLICK”, which means functions of front cleaning, rear cleaning and drying are in operation. The nozzle will continue to spray for 1-2 seconds after user stands up during spray operation, so please press “STOP” button before standing up.

Customer Service Phone: 562-229-0088. (Monday - Friday 9 AM - 5 PM Pacific Time)

Or Email: [help@woodbridgebath.com](mailto:help@woodbridgebath.com)